

## ROGOZ AUDIO ANTI-VIBRATION AUDIO PLATFORMS

*Rogoz Audio* manufactures specialist anti-vibration furniture: audio stands, speaker stands, and platforms. Our offer is aimed primarily at audiophiles, music lovers, and music business professionals, as well as all those who appreciate high quality of sound and design. Our ultimate goal is creating products eliminating interference between audio components to make it possible for every audio system to reach its maximum effectiveness so that the listeners will enjoy the best possible sound quality.

The furniture and anti-vibration accessories are designed for top quality audio components. A whole structure has been tuned by means of special blending of alloy steel and high carbon content steel. Decoupling and high-precision leveling is achieved by means of adjustable anti-vibration spikes. Some furniture incorporates soft anti-vibration pads to separate parts of the overall structure.

A unique feature of our company is extreme flexibility. A regular price allows for certain modifications, and as a result each product is manufactured on a made-to-order basis. Major alterations of our standard products are also possible and are priced individually. Possible changes in standard patterns involve:

- all sizes
- the kind of frames of audio and speaker stands
- the kind of tops and shelves of audio stands
- the shape of speaker stand tops
- the kind of decoupling

## ROGOZ AUDIO ANTI-VIBRATION PLATFORM

### TECHNICAL DESCRIPTION

- Overall height: 170 mm
- Overall width: 550 mm
- Overall depth: 450 mm
- Leg profile: steel pipes  $\varnothing 80$  mm
- Platform top: 550 x 450 x 40
- Maximum load: up to 150 kg
- Ballast: quartz sand

### A COMPLETE SET INCLUDES:

- 1 steel frame
- 1 platform top (MDF and wood veneer)
- 6 adjustable spikes
- 3 separating disks
- 3 massive anti-scratch disks protecting the floor

### APPLICATIONS

- CD players;
- Analog gramophones
- Power amplifiers
- Integrated amplifiers
- Preamplifiers
- Loudspeakers



Three-legged platform. The legs contain quartz sand as ballast. The frame color: black (matt, fine grain). The 40 mm thick top is made of wood (MDF), covered in natural wood veneer (walnut).

Anti-vibration platforms are designed for high end audio components. The frame has been tuned by a suitable combination of alloy steel and high-fiber content steel. The frame consist of extra-strong legs made of carbon steel S235JR (which is used for load-bearing stuctures subject to heavy dynamic load, e.g. in cranes) connected by crosspieces made from higher-strength alloy steel S355. Adjustable anti-vibration spikes are used for for high-precision leveling.

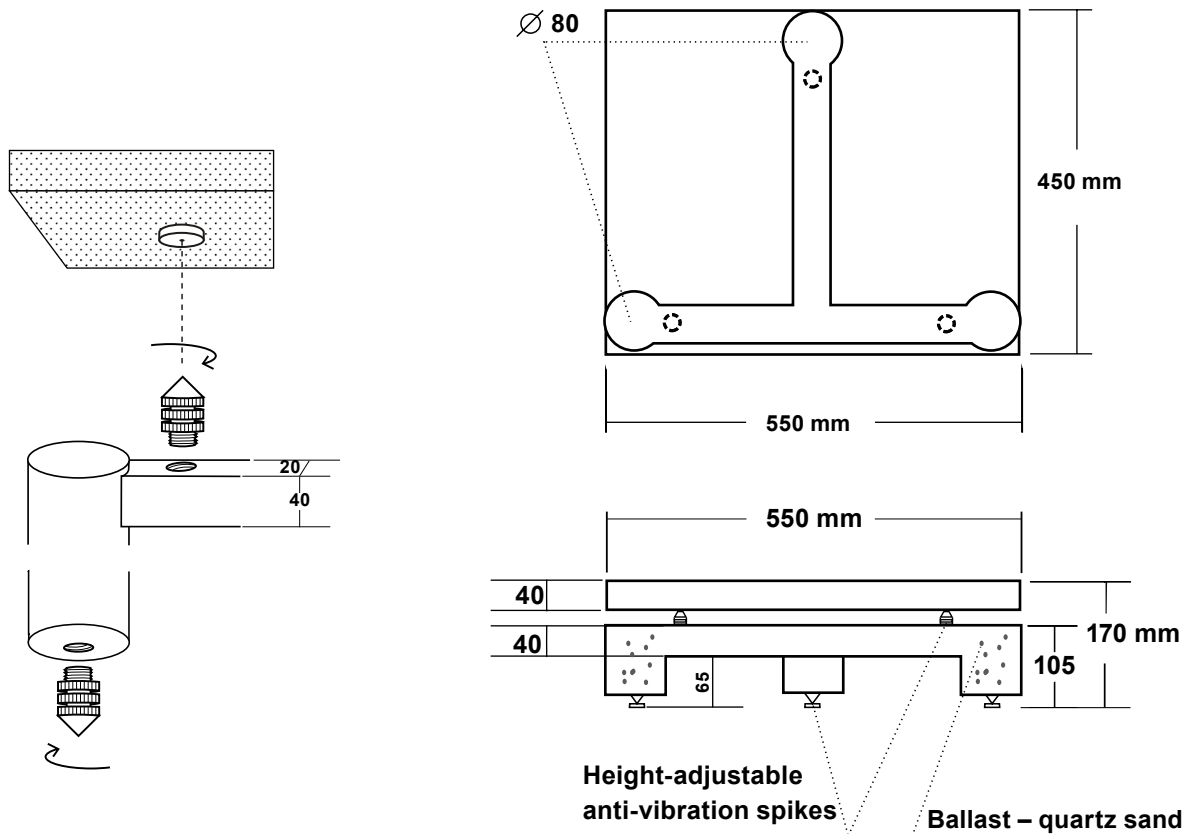

Gross weight including the packaging and pallet **25 kg**

ROGOZ AUDIO ANTI-VIBRATION PLATFORM

TECHNICAL DESCRIPTION

- Weight: 5,8 kg
- Overall height: 60 mm
- Top thickness: 40 mm
- Overall width: 492 mm
- Overall depth: 420 mm
- Maximum load: up to 100 kg



A COMPLETE SET INCLUDES:

- 1 platform top (plywood, MDF, and wood veneer)
- 4 height-adjustable spikes
- 4 separating disks

Anti-vibration platform with „sandwich” structure: plywood, MDF, and sapeli mahogany wood veneer.

APPLICATIONS

- CD players
- Analog gramophones
- Power amplifiers
- Integrated amplifiers
- Preamplifiers
- Loudspeakers

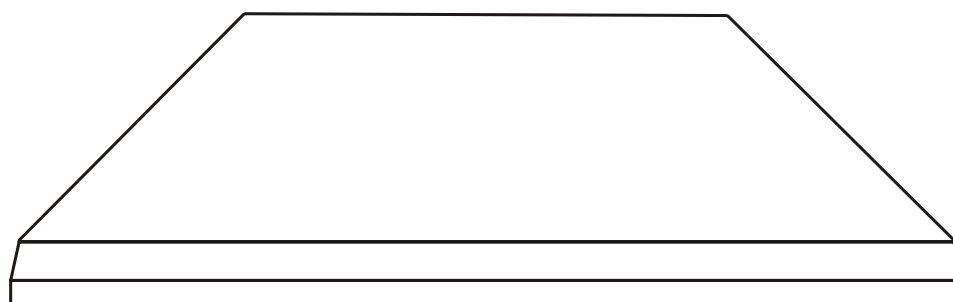
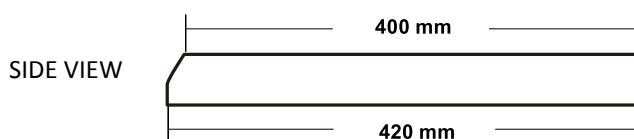
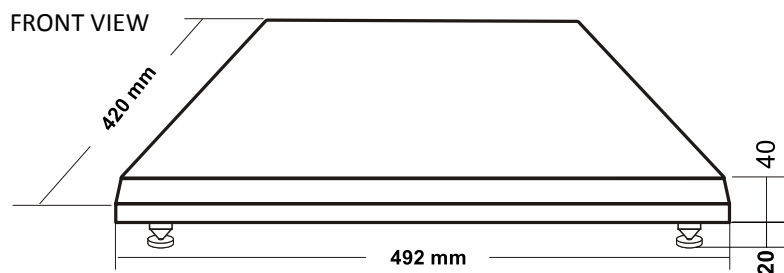
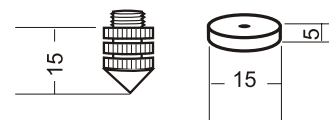

Gross weight including the packaging and pallet **10 kg**

## ROGOZ AUDIO ANTI-VIBRATION PLATFORM

### TECHNICAL DESCRIPTION

- Overall height: 180 mm
- Overall width: 550 mm
- Overall depth: 450 mm
- Leg profile: steel pipes  $\varnothing 80$  mm
- Platform top: 550 x 450 x 50 mm
- Maximum load: up to 150 kg
- Ballast: quartz sand



### A COMPLETE SET INCLUDES:

- 1 steel frame
- 1 platform top (MDF and wood veneer)
- 4 adjustable spikes
- BBS under the shelf
- 3 massive anti-scratch disks protecting the floor

Four-legged platform. The legs contain quartz sand as ballast. The 50 mm thick top is made of wood (MDF), covered in natural wood veneer (rosewood).

The shelf is separated from the stand frame by the Balancing Board System. BBS has kinematic and dynamic qualities which enable isolated masses to “float” to the sides relative to the system axis, maintaining point support at the same time. BBS also makes it possible to level the stand shelves.

Anti-vibration platforms are designed for high end audio components. The frame has been tuned by a suitable combination of alloy steel and high-fiber content steel. The frame consist of extra-strong legs made of carbon steel S235JR (which is used for load-bearing sturctures subject to heavy dynamic load, e.g. in cranes) connected by crosspieces made from higher-strength alloy steel S355. Adjustable anti-vibration spikes are used for for high-precision leveling.

### APPLICATIONS

- CD players;
- Analog gramophones
- Power amplifiers
- Integrated amplifiers
- Preamplifiers
- Loudspeakers

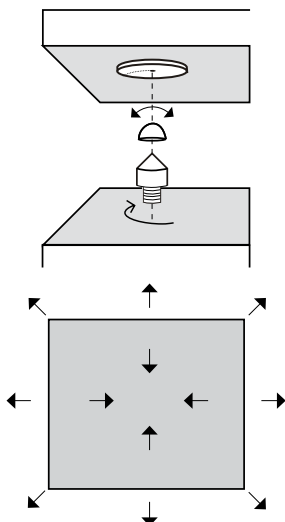

**BBS** BOARD BALANCING INVOLVES HORIZONTAL PLANE MOVEMENT IN ALL DIRECTIONS

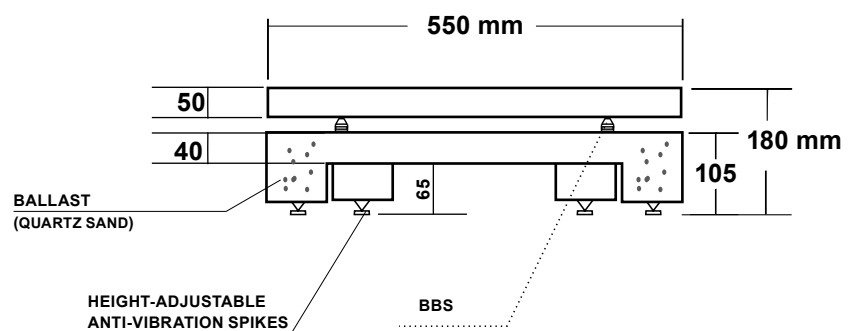
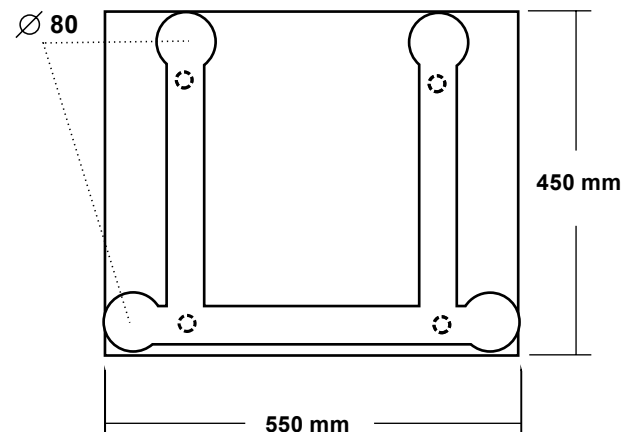

Gross weight including the packaging and pallet **30 kg**

## ROGOZ AUDIO ANTI-VIBRATION PLATFORM

### TECHNICAL DESCRIPTION

- Overall height: 165 mm;
- Overall width: 613.7 mm;
- Overall depth: 702.1 mm;
- Top shelf: 613.7 x 702.1 x 70 mm;
- Bottom shelf: 613.7 x 702.1 x 80 mm;
- Weight: 40 kg (190 kg including TAD R1 speaker);
- Maximum load: up to 200 kg.



### A COMPLETE SET INCLUDES:

- 1 top shelf (MDF/HDF);
- 1 bottom shelf (MDF/HDF);
- 3 handles (INOX);
- 6 BBS sets.

Anti-vibration platform 6T2R1/BBS has been designed for TAD Reference One loudspeaker. It is black with semi-matte finish. The platform consists of two shelves 80 and 70 mm thick, respectively, separated from each other at six points by BBS. The Balancing Board System (BBS) has kinematic and dynamic qualities which enable isolated masses to “float” to the sides relative to the system axis, maintaining point support at the same time. BBS also makes it possible to level the platform. The underside of the bottom shelf can be ordered in either of the following two versions:

### APPLICATIONS

The platform is designed for TAD Reference One speaker. On request, it can be altered to fit other audio equipment:

- CD players;
- analog gramophones;
- power amplifiers;
- integrated amplifiers;
- preamplifiers;
- other loudspeakers.

(a) backed with a thick layer of felt, enabling the platform with a loudspeaker to slide across the smooth surface of the floor (for your convenience, three specially designed handles can be driven into the sockets situated on the sides of the bottom shelf);

(b) fitted with six adjustable spikes and massive protective disks, enabling the platform to be placed firmly on soft or rough and coarse surfaces.

The anti-vibration platform 6T2R1/BBS can be customized (on request) to fit any speaker, amplifier, gramophone, CD/DVD/Blu-ray player or other audio equipment.

The platform is designed for high end audio components. Its structure has been tuned by a suitable combination of MDF, HDF, steel components (INOX, A10X, N23), and carbon polymer.

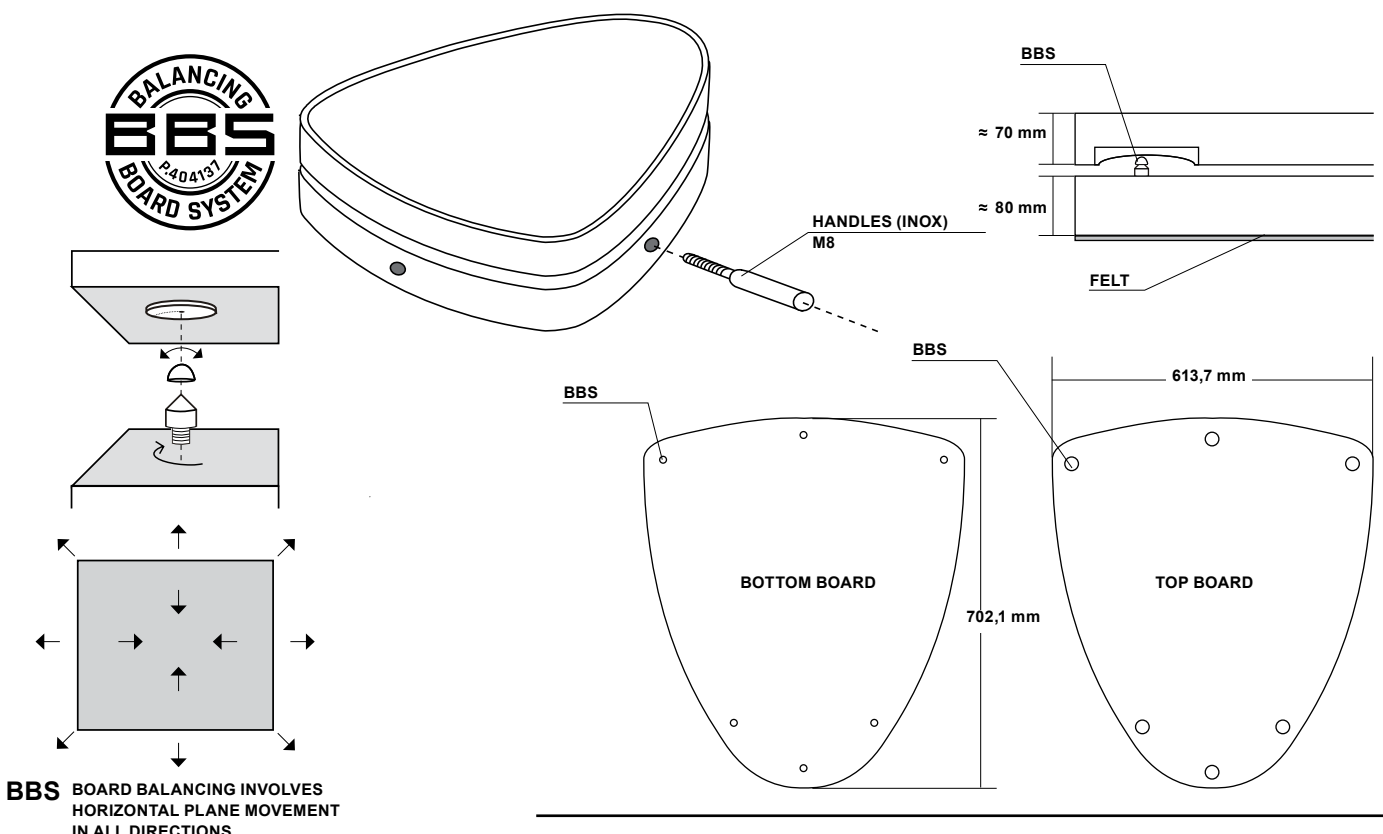

Gross weight including the packaging and pallet **50 kg**

## ROGOZ AUDIO ANTI-VIBRATION PLATFORM

### TECHNICAL DESCRIPTION

- Overall height: 142 mm
- Overall width: 600 mm
- Overall depth: 460 mm
- Leg profile: 165 x 60 mm
- Usable shelf: 460 x 460 x 30 + 30 mm
- Maximum load: up to 100 kg



### A COMPLETE SET INCLUDES:

- 1 platform
- 4 height-adjustable spikes
- BBS between shelves
- 4 massive anti-scratch disks protecting the floor

### APPLICATIONS

- CD players;
- Analog gramophones
- Power amplifiers
- Integrated amplifiers
- Preamplifiers
- Loudspeakers

Anti-vibration platform with „sandwich” structure. Double shelves 2 x 30 mm thick are separated by BBS. BBS has kinematic and dynamic qualities which enable isolated masses to “float” to the sides relative to the system axis, maintaining point support at the same time. BBS also makes it possible to level the stand shelves. Anti-vibration stands are designed for high end audio components.

The audio platform structure incorporates a new proprietary Rogoz Audio antivibration system, BBS (Balancing Board System, Patent P.404137 Pending). The system consists of a threaded, height-adjustable spike made of high-fiber-content steel alloy, on top of which two elements are placed, each with an inner bearing. An intermediary (middle) element is made of carbon fiber and supports another element, a steel bearing inserted into the shelf. Point contact between the steel spike and the carbon intermediary element prevents movement of either element relative to its axis, but it allows pendular motion. Meanwhile, the contact between the intermediary element and the bearing inserted into the shelf allows restricted rolling motion and sliding motion. Consequently, the advantages of spike point support (contact area has been minimized and kinetic energy turns into heat) have been combined with the effects of deadening vibrations owing to to sliding friction and rolling resistance.

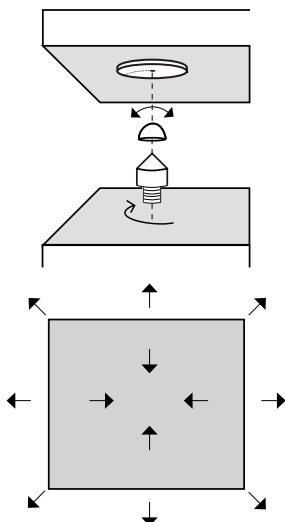

**BBS** BOARD BALANCING INVOLVES HORIZONTAL PLANE MOVEMENT IN ALL DIRECTIONS

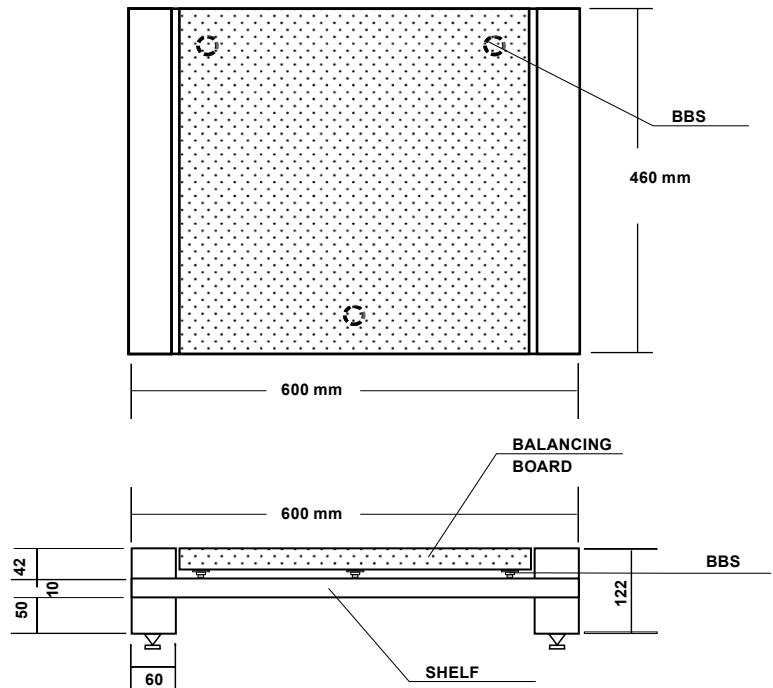

Gross weight including the packaging and pallet **30 kg**



## ROGOZ AUDIO ANTI-VIBRATION PLATFORM

### TECHNICAL DESCRIPTION

- Overall height: 202 mm
- Overall width: 700 mm
- Overall depth: 520 mm
- Leg profile: sandwich MDF+MDF+HDF 50 mm thick
- Top shelf: sandwich MDF+MDF+HDF 700 x 520 x 50 mm
- Middle shelf: sandwich MDF+MDF+HDF 700 x 520 x 50 mm
- Bottom shelf: sandwich MDF+MDF+HDF 700 x 520 x 50 mm
- Maximum load: up to 150 kg

### A COMPLETE SET INCLUDES:

- 1 platform
- 4 height-adjustable spikes or 4 wheels with 2 breaks
- triple BBS between three shelves and four legs

### APPLICATIONS

- CD players;
- Analog gramophones
- Power amplifiers
- Integrated amplifiers
- Preamplifiers
- Loudspeakers

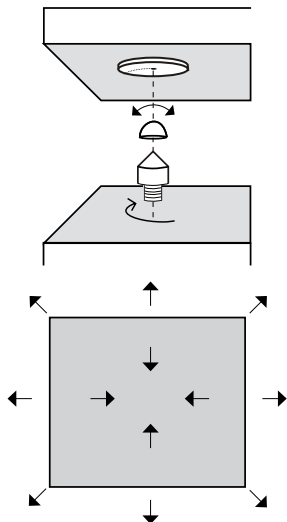

**BBS** BOARD BALANCING INVOLVES HORIZONTAL PLANE MOVEMENT IN ALL DIRECTIONS



Anti-vibration platform with „sandwich” structure. Triple shelves 3 x 50 mm thick and bases 50 mm thick are separated by BBS. BBS has kinematic and dynamic qualities which enable isolated masses to “float” to the sides relative to the system axis, maintaining point support at the same time. BBS also makes it possible to level the stand shelves. Antivibration platforms are designed for high end audio components. The audio platform structure incorporates a new proprietary Rogoz Audio antivibration system, BBS (Balancing Board System, Patent P.404137). The system consists of a threaded, height-adjustable spike made of high-fiber-content steel alloy, on top of which two elements are placed, each with an inner bearing. An intermediary (middle) element is made of carbon fiber and supports another element, a steel bearing inserted into the shelf. Point contact between the steel spike and the carbon intermediary element prevents movement of either element relative to its axis, but it allows pendular motion. Meanwhile, the contact between the intermediary element and the bearing inserted into the shelf allows restricted rolling motion and sliding motion. Consequently, the advantages of spike point support (contact area has been minimized and kinetic energy turns into heat) have been combined with the effects of deadening vibrations owing to to sliding friction and rolling resistance.

The underside of the bottom shelf can be ordered in either of the following two versions:

(a) fitted with six adjustable spikes and massive protective disks, enabling the platform to be placed firmly on soft or rough and coarse surfaces.

(b) fitted with four wheels with two brakes

The platform is designed for high end audio components. Its structure has been tuned by a suitable combination of MDF, HDF, steel components (INOX, A10X, NZ3), and carbon polymer.

The photographs show a platform designed for Studer A80 reel tape recorder. On request, it can be altered to fit other audio equipment:

- CD players;
- Analog gramophones
- Power amplifiers
- Integrated amplifiers
- Preamplifiers
- Loudspeakers

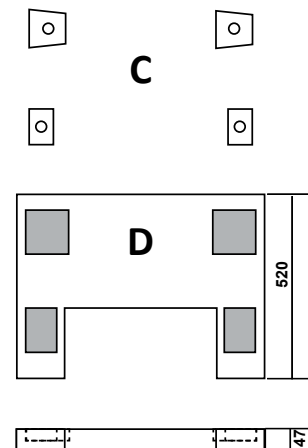
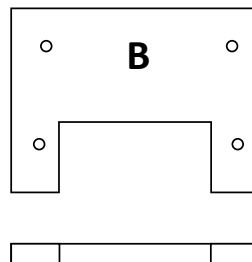
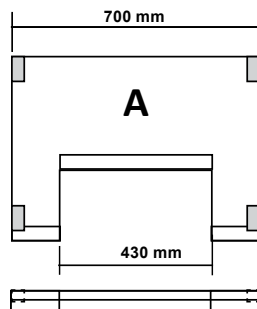

Gross weight including the packaging and pallet **40 kg**



## ROGOZ AUDIO ANTI-VIBRATION PLATFORM

### TECHNICAL DESCRIPTION

- Overall height: - 70 mm;
- Overall width: – 147 mm;
- Overall depth – 130 mm;
- Top shelf: - 147 x 130 x 30 mm;
- Bottom shelf - 147 x 130 x 25 mm;

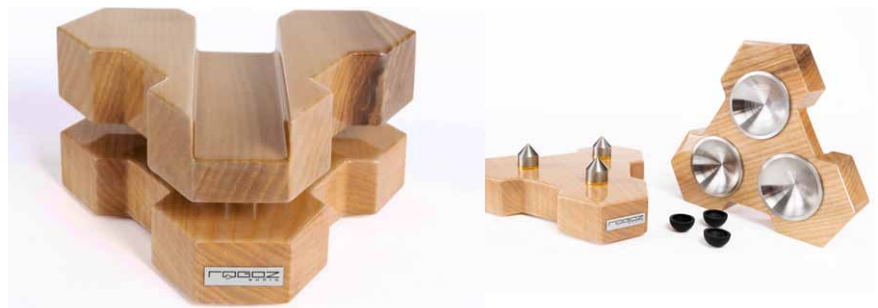

### A COMPLETE SET INCLUDES:

- 1 platform
- BBS between shelves

The platform consists of two shelves, 30 and 25 mm thick, separated from each other at three points by BBS (Balancing Board System). The shelves are made of ash wood with glossy piano finish.

Kinematic and dynamic properties of BBS enable isolated masses to ‘float’ sideways relative to the system axis, maintaining point support at the same time. Furthermore, BBS makes it possible to level the platform.

The platform is designed for high-end components. Its structure has been tuned by combining several materials: MDF, HDF, exotic wood, and steel elements (inox, A10X, NZ3), and carbon fibre.

### APPLICATIONS

- speaker cables;
- interconnects;
- power cables;

Depending on the circumstances (mainly on the length and type of cables), one or more platforms are used for each cable. In some situations, one platform might be sufficient for two cable types (for example, speaker and signal cables), provided they do not touch each other.

The platform structure incorporates a new proprietary Rogoz Audio antivibration system, BBS (Balancing Board System, Patent P.404137 Pending). The system consists of a threaded, height-adjustable spike made of high-fiber-content steel alloy, on top of which two elements are placed, each with an inner bearing. An intermediary (middle) element is made of carbon fiber and supports another element, a steel bearing inserted into the shelf. Point contact between the steel spike and the carbon intermediary element prevents movement of either element relative to its axis, but it allows pendular motion. Meanwhile, the contact between the intermediary element and the bearing inserted into the shelf allows restricted rolling motion and sliding motion. Consequently, the advantages of spike point support (contact area has been minimized and kinetic energy turns into heat) have been combined with the effects of deadening vibrations owing to to sliding friction and rolling resistance.

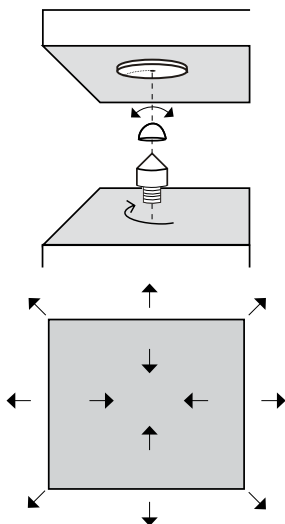

**BBS** BOARD BALANCING INVOLVES HORIZONTAL PLANE MOVEMENT IN ALL DIRECTIONS

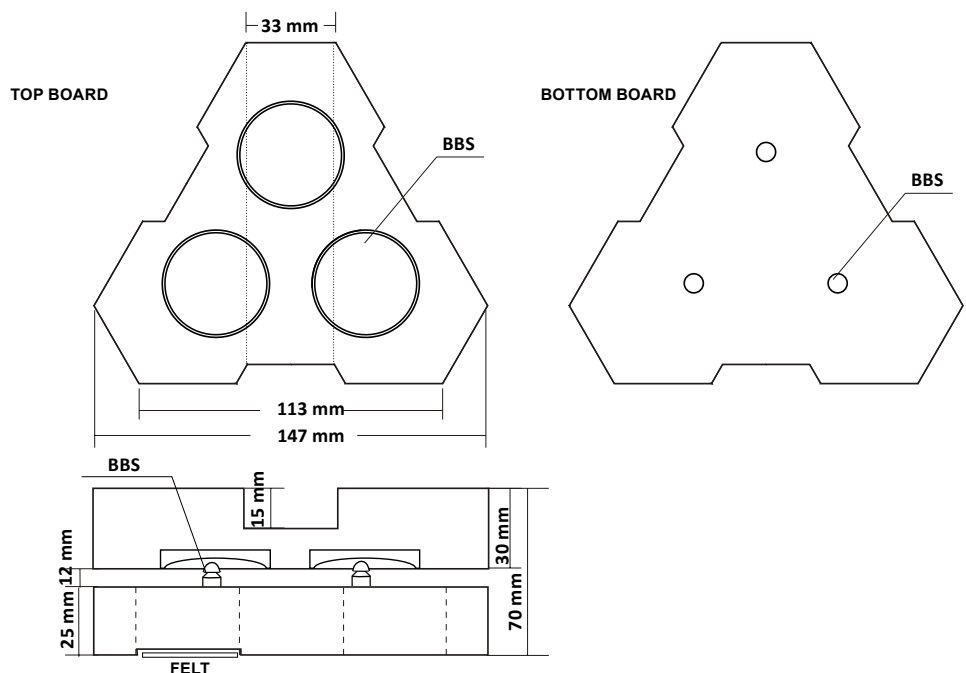

Gross weight including the packaging and pallet

## ROGOZ AUDIO ANTI-VIBRATION PLATFORM

### TECHNICAL DESCRIPTION

- Overall height: 116 mm
- Overall width: 590 mm
- Overall depth: 540 mm
- Leg profile: sandwich MDF+MDF+HDF 30 mm thick
- Top shelf: sandwich MDF+MDF+HDF 500 x 470 x 30 mm / 420 x 430 x 30 mm (surface without chamfer)
- Bottom shelf: sandwich plywood + plywood 500 x 470 x 30 mm
- Maximum load: up to 60 kg

### A COMPLETE SET INCLUDES:

- 1 platform
- double BBS between two shelves and two bases

### APPLICATIONS

- CD players;
- Analog gramophones
- Power amplifiers
- Integrated amplifiers
- Preamplifiers
- Loudspeakers



Anti-vibration platform with „sandwich” structure. Double shelves 2 x 30 mm thick and bases 30 mm thick are separated by BBS. BBS has kinematic and dynamic qualities which enable isolated masses to “float” to the sides relative to the system axis, maintaining point support at the same time. BBS also makes it possible to level the stand shelves. The shelves are covered with natural wood veneer (in the version shown, it is high gloss maple wood). Antivibration platforms are designed for high end audio components.

The audio platform structure incorporates a new proprietary Rogoz Audio antivibration system, BBS (Balancing Board System, Patent P.404137). The system consists of a threaded, height-adjustable spike made of high-fiber-content steel alloy, on top of which two elements are placed, each with an inner bearing. An intermediary (middle) element is made of carbon fiber and supports another element, a steel bearing inserted into the shelf. Point contact between the steel spike and the carbon intermediary element prevents movement of either element relative to its axis, but it allows pendular motion. Meanwhile, the contact between the intermediary element and the bearing inserted into the shelf allows restricted rolling motion and sliding motion. Consequently, the advantages of spike point support (contact area has been minimized and kinetic energy turns into heat) have been combined with the effects of deadening vibrations owing to to sliding friction and rolling resistance.

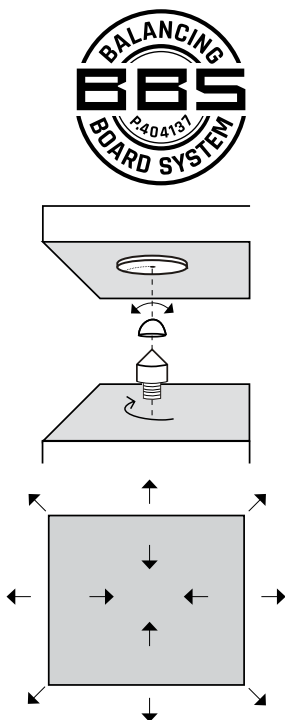

**BBS** BOARD BALANCING INVOLVES HORIZONTAL PLANE MOVEMENT IN ALL DIRECTIONS

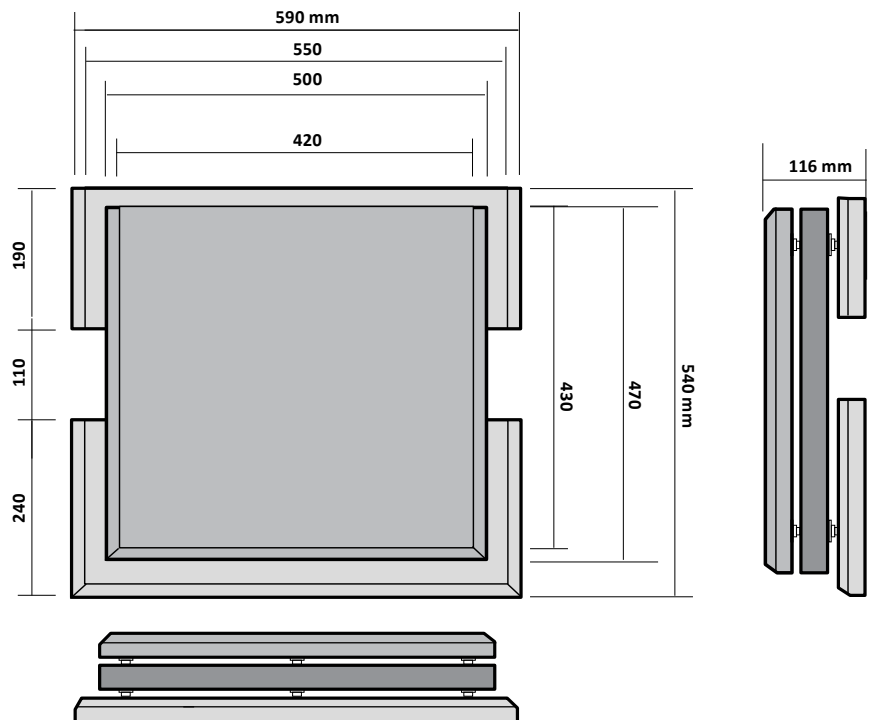

Gross weight including the packaging and pallet **30 kg**

## INSTRUCTION FOR USE

Wood veneer is a natural product, and its pattern, hue or tint might vary slightly, just like individual same-species trees in a forest differ from one another (depending on their age and environment factors influencing tree growth, like the soil's chemical properties, local climate, sun exposure, etc.) This is why producing every piece of furniture or furniture set covered with wood veneer always requires veneer obtained from the same tree trunk.

If, on a future occasion, one chooses the same kind of veneer to match already existing furniture, there will always be noticeable hue and pattern differences. Those differences usually tend to diminish with the passage of time, due to color darkening and the patina that wood acquires, which are natural processes. Newly laid veneer on furniture undergoes a natural process of darkening caused by sunlight and atmospheric gases – mainly during the first eight weeks. This is especially noticeable with cherry, walnut, and oak veneer, but it can also be present with all other kinds, to various degrees. In the areas with no light exposure, the veneer will remain lighter. This is the case especially in the early stages of using veneered furniture. While the furniture is being used, it is highly advisable to regularly move around the objects placed on it, in order to obtain a uniform color tone of the veneer (and consequently to avoid light patches shaped like the objects placed on a veneered surface).

Due to the same wood characteristic, it might take quite some time before its hue gets to harmonize with older objects made of the same material. Proper wood care requires soft and slightly damp dust cloth. Veneer must be prevented from long-term exposure to water, so a wet cloth should not be left lying on veneer. Wooden surfaces need to be protected from damage by means of special pads, preventing direct contact with materials that might be harmful from a chemical or mechanical point of view (e.g. coloring materials or sharp-edged objects).